

# **IMAG Drift Calculator v1.1**

## **User manual**

Belonging to release 1.1.001/2003.02.05

H.J.Holterman  
J.C. van de Zande

IMAG  
Draft Report, 7 February 2003

## **Preface**

Some time ago, the idea came up to construct a small calculator program to estimate spray drift to surface waters. Especially some researchers in the FOCUS Surface Water Scenarios Working Group asked for a quantification of spray drift as an input for their models. The idea was transferred into a small software application, and gradually it grew bigger and more sophisticated. This manual accompanies the first release of this program: the IMAG Drift Calculator. In its present form it is loosely connected to Alterra's pesticide fate model TOXSWA (e.g. currently software installation is from within the TOXSWA software package), yet the IMAG Drift calculator remains a software application on its own. The authors would like to thank Mrs. Paulien Adriaanse from Alterra for a pleasant and fruitful co-operation which has yielded some clearly synergic advantages for both TOXSWA and the IMAG Drift Calculator.

This project is part of research programme 359 (Emission, emission reduction methods and environmental risk of crop protection agents), granted by the Dutch Ministry of Agriculture, Nature Management and Fisheries (LNV).

# Contents

Summary	4
1 Introduction	5
2 Background to drift curves	8
2.1 Introduction	8
2.2 Spray drift measurements	9
2.3 Arable crops	9
2.3.1 Potato	9
2.3.2 Flower bulbs	10
2.3.3 Sugar beet	10
2.3.4 Cereals	11
2.3.5 Bare soil	11
2.4 Orchard crops	11
2.5 Discussion	12
2.6 Regression curves	13
3 Getting started	14
3.1 Installing the drift calculator	14
3.2 Requirements	14
3.3 Start-up	14
4 Using the IMAG Drift Calculator	16
4.1 Pictogram buttons	16
4.1.1 EXIT button	16
4.1.2 HELP button	17
4.1.3 SAVE button	17
4.1.4 TABLE button	17
4.1.5 CALCZONE button	18
4.1.6 SAVEBMP button	18
4.2 CTB drift table	19
4.3 Refined NL scenarios	21
4.4 FOCUS-like scenarios	25
4.5 Crop free zone calculation	28
5 Data control	29
5.1 Resetting the run index system	29
5.2 The saved data file	29
6 Future developments	31
7 Glossary	32
References	34
Appendix A	37
Appendix B	38

## **Summary**

This user manual describes how to install and use the IMAG Drift Calculator, version 1.1 (release code: 1.1.001/2003.02.05). The IMAG Drift Calculator is a tool to quantify spray drift to surface waters near a sprayed field or orchard. The calculator uses statistically obtained regression curves to calculate spray drift.

Apart from practical instructions how to use the calculator, this manual also provides background information on the drift experiments and regression curves, with reference to papers and reports describing these experiments in detail.

The IMAG Drift Calculator has three major calculation units. The simplest unit is the first tier assessment as used in the Netherlands by the Board for the Authorization of Pesticides (CTB). This ‘CTB drift table’ roughly distinguishes spray drift from several arable and several tree crops. For fruit trees a further distinction is made with respect to growth stage (with or without leaves) and several specific application techniques.

The second unit (‘Refined NL’) accounts for four arable crops, bare ground, and fruit trees (in leaf and leafless). Also the effect of different (non-conventional) application techniques is accounted for. Presently, the only water body onto which spray drift is estimated, is a ‘standardized Dutch ditch’.

The third calculation unit (‘FOCUS-like’) is similar to the ‘Refined NL’ unit. However, more crops can be selected, following a list of crops as used by the FOCUS Working Group on Surface Water Scenarios. Unfortunately, for most of these crops no regression curve for drift calculation is available. To overcome this problem, for each FOCUS-like crop an ‘equivalent crop’ is determined from the list of crops with regression curves (i.e. the crops in the ‘Refined NL’ scenario set). An equivalent crop is selected based on crop type, crop height and global canopy shape. For some crops no matching crop could be found, mainly because the FOCUS-like crop is too different from common crops in the Netherlands, or crop height is too large.

Currently, the IMAG Drift Calculator is limited to only four arable crops, two fruit crop stages, and bare ground. Non-conventional application techniques are only available for a potato crop. These cases imply a total of 12 regression curves. Future development will need to focus on a larger variety in crops and applications, and possibly varying weather conditions as well. Non-standard water bodies (e.g. user defined geometry) is a topic for future development also.

# 1 Introduction

In agriculture, the use of chemicals still is an essential way of protecting the crops against all kinds of harmful plagues. Nevertheless, the application of pesticides should be done with the greatest care to minimize unwanted side-effects and to protect the environment. Common application techniques involve the use of spraying equipment to transfer the chemicals to the target (usually the crop to be protected). Off-target deposits of spray drops should be minimized. Especially, the occurrence of spray deposits onto surface waters adjacent to or near sprayed fields should be avoided.

The last decade many experiments were carried out to investigate downwind spray deposits under varying circumstances (see Chapter 2). Several field crops were involved, as well as fruit crops. The experiments were analysed statistically and the results are available now as regression curves of spray deposits as a function of downwind distance (Chapter 2). The IMAG Drift Calculator, described in this report, uses these curves to calculate spray deposits onto downwind areas specified by external conditions. These conditions mainly consist of crop type and crop free buffer zone (i.e. a measure of the width of ground without vegetation between the crop and an adjacent water body).

Regression curves used in the drift calculator are available for six crops and bare soil (see Table 1). For potato crops several application techniques are available. The common technique for pesticide spraying in the Netherlands is an application using a ‘conventional’ boom sprayer, equipped with medium-sized flat fan nozzles. Additional techniques consist of variation in height of the sprayer boom above the crop, different type of nozzles used, and the use of ‘air assistance’ (i.e. using a downward air stream to guide drops towards the crop). For fruit crops a cross-flow sprayer is commonly used. Further specification of the techniques is given in Appendix A.

**Table 1.** Crop types and application techniques available for calculation of downwind spray deposits.

Crop type	Application type
Potato	Conventional boom sprayer (=Conv.)
	Conv., with raised boom
	Conv., with air assistance
	Conv., with raised boom & air assistance
	Conv., with drift reducing nozzles
	Conv., with drift reducing nozzles & air assistance
Flower bulb	Conventional boom sprayer
Sugar beet	Conventional boom sprayer
Cereals	Conventional boom sprayer
Fruit trees, in leaf	Cross-flow sprayer for fruit crops
Fruit trees, leafless	Cross-flow sprayer for fruit crop
Bare soil	Conventional boom sprayer

The IMAG Drift Calculator has three main calculation units (Figure 1). The first unit is the CTB drift table, as used by the Board for the Authorization of Pesticides in the Netherlands (CTB) (CTB website, based on: Huijsmans, et al., 1999; Van de Zande, et al., 2001). In fact using this table involves no calculations at all, though the drift values in the table are deduced from the previously mentioned curves. The CTB table merely offers a general, first estimation of spray drift to an adjacent ditch downwind.

The second calculation unit is the ‘Refined NL Scenarios’ unit. In this unit a refinement with respect to crop type and application technique is made, according to Table 1. It offers a better approach to drift estimation, by taking into account the effects of different crop types and spraying equipment. In the present set-up the water body still is limited to a standardized Dutch ditch (Huijsmans, et al., 1997). Though this unit is oriented to situations in the Netherlands, it also can be applied to similar situations abroad.

The third calculation unit offers the possibility to calculate spray drift for situations defined by the FOCUS group on pesticide fate in surface waters (FOCUS, 2002). In these FOCUS-like scenarios the essential parameters for crop type and water body type are copied from the FOCUS surface water scenarios. Since the actual calculation of drift still is based on the limited set of regression curves mentioned before, often no exact match is found for a FOCUS-like scenario. Therefore a best choice is made from the available set of drift curves, mainly based on crop type and crop height. This best choice is referred to as ‘equivalent crop’. Though the name suggests a crop only, it also implies a certain application technique (marked as *conventional*). Some FOCUS-like crops differed too much from crops in the available set, and no equivalent crop was selected. In general, all relatively high FOCUS-like field crops and fruit crops could not be matched, and consequently no spray drift can be estimated for these crops. In some cases the shape of crop canopy differed too much from those in the Refined NL set, often because such crops are not grown in the Netherlands. Appendix B, Table B.1 gives a full list of FOCUS-like crops, their equivalent crops and criteria for non-matching cases. Though currently in the FOCUS surface water scenarios no distinction is made regarding different application techniques, in the calculation unit for FOCUS-like scenarios the set of scenarios can be extended with non-conventional application techniques. Clearly, from Table 1, at the moment this only concerns crops which equivalent crop is potato.

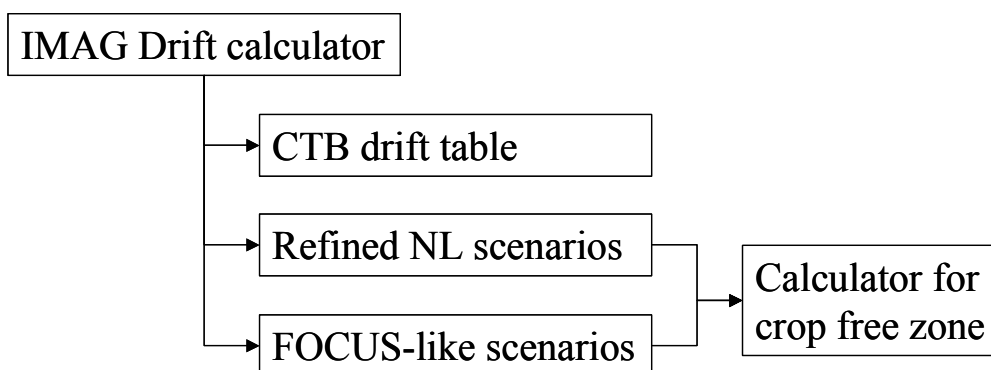

**Figure 1** General view of the IMAG Drift Calculator; main calculation units.

A fourth, second-stage unit involves the calculation of crop free zone when a certain drift value is specified. This unit is only accessible from the Refined NL and FOCUS-like scenarios, and uses the settings made in those units (like crop type, application, water body type).

## 2 Background to drift curves

### 2.1 Introduction

The emissions of plant protection products to soil, (surface) water and air should be reduced. A general reduction in spray drift to surface water next to the sprayed field can be achieved by improvements in spray application techniques. For the last 10 years an intensive measuring programme on spray drift has been performed. The research programme consisted of laboratory measurements, field experiments and computer modelling. A system analysis approach was developed to divide the research into processes and parts important for spray drift: the nozzle (drop sizes, spray quality, driftability), sprayer boom movement and boom height (drop trajectory), sprayer outline and additional drift reducing technology on it, the crop type (height, density, and the placement of the last nozzle to the edge of the crop), the field layout and the place of the surface water.

The programme started with the quantification of the drift for the reference situation of the Multi Year Crop Protection Plan (MYCPP, 1991) and addressed whether the set 2% drift level was a true value for common agricultural practice in arable farming. A stepwise approach was chosen to lower drift with air assistance or shielding sprayer booms on a field sprayer, a tunnel sprayer, sprayer boom height and nozzle type.

In order to apply a risk assessment the results are to be presented on a uniform basis and expressed as percentage of the application rate per surface area, at a chosen 'evaluation range' of 2.25-3.25 m from the last row of potatoes or 4.5-5.5 m from the last row of trees (orchards). This evaluation range is the place where ditches are commonly situated in the Netherlands (Figure 2).

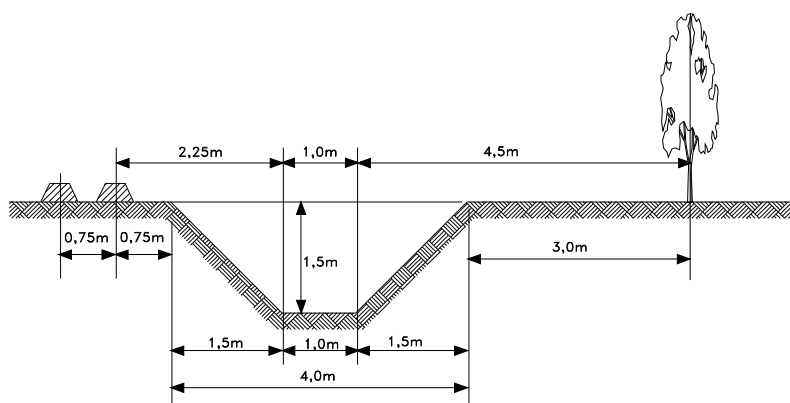

**Figure 2** Representation of the place of the ditch, embankments and water surface, and the last rows of a potato crop (left-hand side) and a tree row in an orchard (right-hand side) (Huijsmans, et al., 1997).

## 2.2 Spray drift measurements

In a series of field experiments in a potato crop during the growing season air-assisted spraying was compared to conventional spraying. The effect of drift reducing nozzles on spray drift and the effect of a no-spray buffer zone was quantified as well. Measurements were done on a bare soil surface and in a ditch, downwind of the crop. The fluorescent dye Brilliant Sulfo Flavine (BSF) was added as a tracer to the spray liquid. Drift collectors were placed inside and outside the field. The swath-width sprayed was at least 18m (i.e. the full width of the sprayer boom). The length of the sprayed track was at least 50m. Spray drift was measured in at least ten replications, at different places along the edge of the field and at different times during the growing season. The distance of the last downwind nozzle to the edge of the field (the outer crop leaves) was determined. All measurements of spray drift included a reference measurement, which involved a conventional field sprayer applying a volume rate of 300 l/ha with a medium (M) spray quality. In case of air assistance, nozzles sprayed vertically downward and air velocity was set to the maximum capacity of the fan.

Ground deposits were measured on two rows of horizontal collection surfaces, slightly separated, placed at ground level downwind of the sprayed swath (0-16 m from the last nozzle). Collectors used were synthetic cloths with dimensions of 0.50x0.08 and 1.00x0.08 m<sup>2</sup>. After spraying, the dye was extracted from the collectors and concentration was determined by fluorimetry. Results of spray drift were expressed as percentage of the application rate of the sprayer (spray dose).

Meteorological conditions during spray drift measurements were recorded. Wind speed and temperature were measured at 5 s interval at 0.5 and 2.0 m height, using cup anemometers and Pt100 sensors, respectively. Relative humidity was measured at 0.5 m height and wind direction at 2.0 m height.

Spray drift results were analyzed statistically using analysis of variance (ANOVA 5% probability).

## 2.3 Arable crops

### 2.3.1 Potato

The reference situation for the MYCPP for field crop spraying was a conventional boom sprayer spraying a potato crop during the growing season with an average wind speed of 3 m/s. Crop height was on average 0.5 m above soil surface and sprayer boom height was 0.7 m above the crop canopy. Spray volume was 300 l/ha, using a flat fan nozzle-type (BCPC-class Medium; Southcombe, et al., 1997).

#### *Effect of spray volume*

In a first series of experiments the effect of spray volume and air assistance on spray drift was quantified. A number of drift measurements was executed in the period 1992-1994 (Porskamp et al., 1995). Spray volumes compared were 150 l/ha and 300 l/ha, corresponding to a fine (F) and a medium (M) spray quality (Southcombe, et al., 1997). Sprayer boom height was set to 0.7 m above the canopy. Within this volume range the

spray quality did not significantly affect the drift deposition. Compared to conventional spraying, a field boom sprayer with air assistance achieved 50% reduction in spray drift on the soil surface at the evaluation range (see Section 2.1).

#### *Effect of nozzle type and air assistance*

In 1997 and 1998 field tests on spray drift were done to quantify the effect of a drift reducing nozzle type and air assistance (Michielsen & van de Zande, 1998; Michielsen et al., 1999). A 'Hardi Twin' field sprayer was used, with and without air assistance. Nozzle types were standard flat fan nozzles (XR11004, 300 kPa, 300 l/ha) and a drift reducing nozzles (DG11004, 300 kPa, 300 l/ha). Driving speed was the same in all experiments. Sprayer boom height was adjusted to 0.5 m above the crop canopy. Crop height was 0.5 m. Using the drift reducing nozzles, a reduction of about 60% in spray drift onto the evaluation range could be achieved. The use of air assistance (maximum air, nozzles spraying vertical) reduced spray drift by about 70%, for both nozzle types. The applications with drift reducing nozzles also involve the use of 'edge' nozzles to avoid spraying directly over the edge of the crop, and a crop free zone increased to 1.5 m (conventionally 0.75 m).

#### *Effect of boom height*

Based on the experiments with sprayer boom height at 0.7 m (experiments 1992-1994) and at 0.5 m (experiments 1997-1998) above a 0.5 m potato crop, the spray drift is reduced by 70% for the lower boom experiments with respect to the higher boom experiments, at the evaluation distance (approx. 2-3 m from the last nozzle) having an application rate of 300 l/ha (conventional nozzles). With the lower boom experiments, additional air assistance further reduced drift by 70%, while for the lower boom experiments an additional reduction of 50% was obtained. Clearly reduction rates of different measures are interrelated.

### 2.3.2 Flower bulbs

In a series of experiments in a flower-bulb crop (1993-1996) spray drift was measured on the ground next to the sprayed field (Porskamp, et al., 1997). Sprayers were equipped with flat fan nozzles, either type XR11003 or XR11004 sprayed at 300 kPa liquid pressure. Sprayer boom height was set to 0.5 m above a crop canopy of on average 0.3 m. Field experiments were performed in tulips, lilies or a flower bulb look-alike crop (cut mustard). No effect of crop type was found on spray drift data. No effect of nozzle type was found either. Average wind speed at 2 m height was 4.1m/s (range: 1.5-8.5) at an averaged temperature of 18°C.

### 2.3.3 Sugar beet

De Jong et al. (2000) describe spray drift experiments in sugar beet. Application rate was 300 l/ha using standard flat fan nozzles (XR11004, 300kPa) with a medium spray quality. Sprayer boom height was adjusted to 0.5 m above the crop canopy (averaged height 0.5 m). Average wind speed at 2 m height was 4.5m/s (range: 1.6-6.0) at an averaged temperature of 17°C.

### 2.3.4 Cereals

In wheat, spray drift experiments were done with different crop heights (Stallinga, et al., 1999). Applied spray volume was 300 l/ha using standard flat fan nozzles (XR11004, 300 kPa) producing a medium (M) spray quality. Crop heights were 0.8 m (winter wheat) and 0.4 m (summer wheat). Additionally, drift experiments on bare soil were done (zero crop height). Sprayer boom height was adjusted to 0.5 m above the crop canopy or soil surface. Average wind speed at 2 m height was 4.4m/s (range: 1.6-6.0) at an averaged temperature of 17°C.

### 2.3.5 Bare soil

Spray drift data on a bare field (zero crop height) were taken from various experiments described above, where bare soil experiments were added for comparison. Experiments included those using a conventional field sprayer and a band-sprayer in a sugar beet or a maize crop (Van de Zande, et al., 2000a) and those cereals (Stallinga, et al., 1999). Crop height of sugar beet (4-8 leaves stage) and maize (3-5 leaves stage) was 10-15 cm. Spray drift was measured spraying a downwind swath of 18m, in 9 repetitions. The sprayer applied 300 l/ha using nozzles of medium spray quality. Sprayer boom height was adjusted to 0.5 m above ground surface. Average wind speed at 2 m height was 4.3m/s (range: 2.8-7.9) at an averaged temperature of 15°C.

## 2.4 Orchard crops

The reference situation for orchard spraying (Figure 3) is an orchard of trees (in leaf), using a cross-flow fan sprayer. In the experiments, leaf area index (LAI) was 1.5-2, and an average wind speed of 3 m/s was measured (range: 1.5-4.0). Air temperature was on average 17°C. Spray drift on the ground was determined at the evaluation range (4.5-5.5 m downwind of the last tree). Spray drift turned out to be 7% of the application rate per unit area of the orchard (Huijsmans et al., 1993); this value is used in the CTB drift table (Section 4.2).

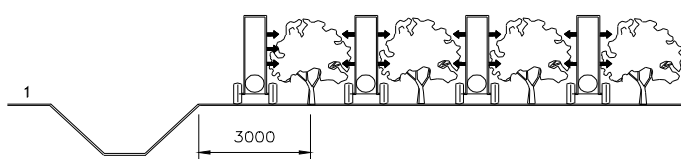

**Figure 3** Representation of the conventional application technique in orchard spraying, using a cross-flow sprayer. Note the single-sided application in the leftmost path (Huijsmans, et al., 1997)

Ganzelmeier et al. (1995) found for an orchard with leafless trees that spray drift was 2-3 times higher than with trees in leaf. This is supported by Van de Zande, et al. (2001). In the IMAG Drift Calculator a factor 2.5 is assumed.

## 2.5 Discussion

The main goal of these studies on spray drift can be defined as good crop protection with minimal environmental burden. Choosing an optimal spray application technique is the obvious next step. To classify applications accordingly, it is essential to define a reference situation for comparison. For potato crops a conventional boom sprayer is chosen as a reference, applying a medium quality spray at 300 l/ha and boom height at 0.50 m above the crop canopy. Crop type and canopy structure affect spray deposition on the target (Van de Zande, et al., 2002) and spray drift (Van de Zande, et al., 2000b). Ganzelmeier et al, (1995), Arvidsson (1997) and SDTF (1997) presented drift curves on cut grass or cereal stubble. Figure 4 shows that these curves can differ by as much as one decade. Apart from the effect of different crop types, differences in measured spray drift can also be attributed to different weather conditions (wind speed and direction), the sprayer swath width, nozzle types, sprayer boom height and sprayer boom movements.

In general, the effects of measures to reduce drift cannot simply be added. E.g. drift reduction with an application involving reduced boom height, air assistance and reduced-drift nozzles does not match the sum of reductions by each of these measures separately (See also section 2.3.1, effect of boom height, with and without air assistance).

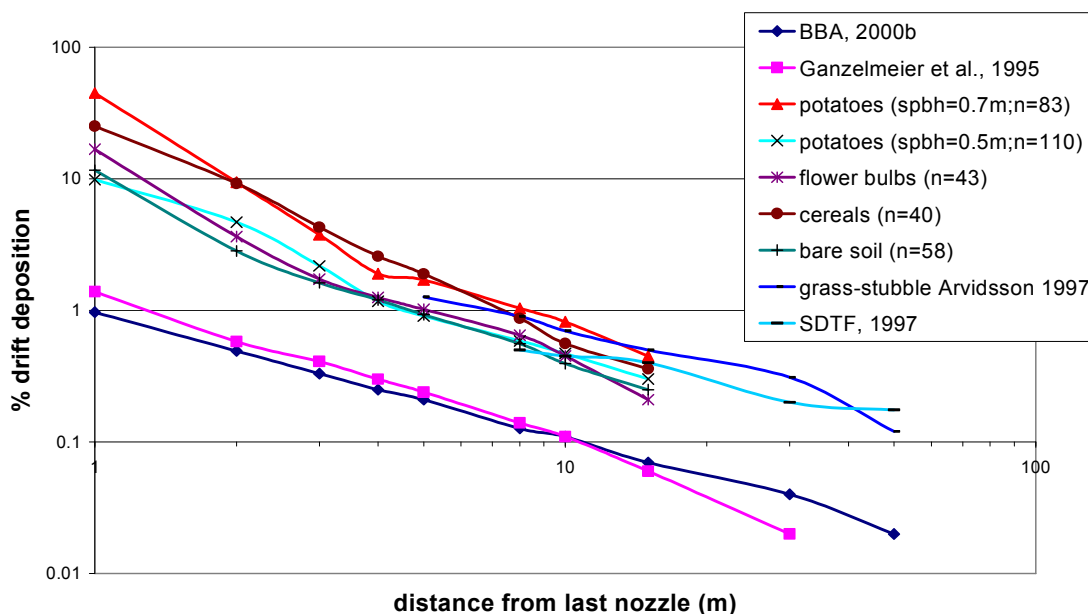

**Figure 4** Effect of crop type and environmental circumstances on spray drift (50-percentiles based on measured data), originating from different sources (*spbh*: sprayer boom height; *n*: number of experiments).

Since spray deposits decrease with increasing downwind distance, increasing the width of an unused zone between crop and water body (i.e. the crop free zone) may be effective in reducing spray drift to surface waters.

The steadily decrease of spray deposits with downwind distance also affects the distribution of deposits onto the water surface. Most of the deposits take place at the side of the water surface closest to the treated field. In all cases however only width averaged drift is given, i.e. averaged over the full width of the water surface. Consequently the averaged load of pesticides onto a wide water body (like a pond) is much lower than that onto a ditch, although the spray application may be the same.

## 2.6 Regression curves

Regression analysis did not show a significant effect of wind speed on spray drift. Therefore the regression curves represent the average for all experiments with a certain crop and application technique. The sum of two exponential functions appeared to be a suitable regression function in most cases:

$$y = A_0 e^{-x/B_0} + A_1 e^{-x/B_1}$$

where  $y$  is downwind spray deposit [% of applied dosage],  $x$  is downwind distance [m] from last nozzle, and  $A_0$ ,  $A_1$ ,  $B_0$ ,  $B_1$  are regression constants. These constants depend on crop type and application technique; constants are listed in Table A.1 (Appendix A).

For a potato crop and an application with raised boom, a power-law function turned out to give a better result:

$$y = A_0 x^{-B_0}$$

Note that in Table A.1 (Appendix A) constants  $A_1$  and  $B_1$  are omitted in this case.

Distance parameter  $x$  is related to the position of the last nozzle. In *Refined NL* scenarios drift also is presented as a function of distance to the last nozzle. In *FOCUS-like* scenarios drift is given as a function of distance to edge of the crop, since FOCUS (2002) essentially does not consider application technique and placement of nozzles. However, one should notice that during the growing season the position of the edge of a crop may change.

In case of fruit trees, distances are commonly related to the position of the last row of trees (i.e position of the stem). For fruit trees, the drift curve for leafless trees is derived from that for trees in leaf: drift is assumed to increase drift by a factor 2.5 (see Section 2.4).

## 3 Getting started

The IMAG Drift Calculator is an independent software application, developed and supplied by the Institute of Agricultural and Environmental Engineering (IMAG), Wageningen, the Netherlands. It is distributed through two channels. The first channel is in combination with the distribution of the TOXSWA software package (Ter Horst, et al., 2002). Installing the drift calculator from within the TOXSWA package is regulated by that package, and is not dealt with in this report. Secondly, the IMAG Drift Calculator can be obtained as a separate software package supplied by IMAG. Installing this package is dealt with in the next section.

### 3.1 Installing the drift calculator

Installing is kept very simple. The self-installing file *IDCinst.exe* unzips three files and copies them into the default folder *c:\Program Files\IMAG Drift Calculator*. If not present, the folder will be created first. The folder name can be set manually just before unzipping, if necessary. The unzipped files are:

- *IDC.exe*: the actual IMAG Drift Calculator program
- *IDCmanual.pdf*: this manual as a PDF file
- *IDC.hlp*: online help file

The file *readme\_IDC.txt* is supplied as a separate file with latest information and instructions.

### 3.2 Requirements

To run the program no additional files are needed. The calculator requires about 620kB disk space; the other files less than 1MB, together. Additional data files (created while running the calculator) require only few kB disk space. A stored bitmap consumes about 600kB disk space. Run-time memory consumption is about 3MB.

The program is developed and tested on systems with Windows NT and Windows 2000, and it is expected to run without problems on systems with Windows 95/98 as well. Fatal run-time errors are expected if the decimal symbol is not set to a dot (.).

### 3.3 Start-up

The drift calculator is started from the Windows Explorer by starting the program file *IDC.exe* (usually by double-clicking the file). It may be convenient to create a shortcut on the desktop or in the start menu.

At first use the program creates a small data file for storing run index numbers (*IDCrunx.dat*). This action is supported by an on-screen message. At subsequent use of the calculator this index file is read (showing an on-screen message if successfully read).

The opening window (Figure 5) shows the main menu:

- general info: provides a short introduction to the calculator;
- CTB drift table: provides the presently used set of drift values in the Netherlands (by the CTB, the Board for the Authorization of Pesticides in the Netherlands)
- refined NL scenarios: calculates spray drift to a standardized Dutch ditch for various crops, for (future) regulatory purposes;
- FOCUS-like scenarios: calculates spray drift for various crops to three standardized water bodies, according to the specifications of the FOCUS Surface Water Scenarios Working Group;
- exit: closes the drift calculator.

The small button in the lower right corner, showing two musical notes, allows to turn on/off the beeps that may occur with various messages during run time.

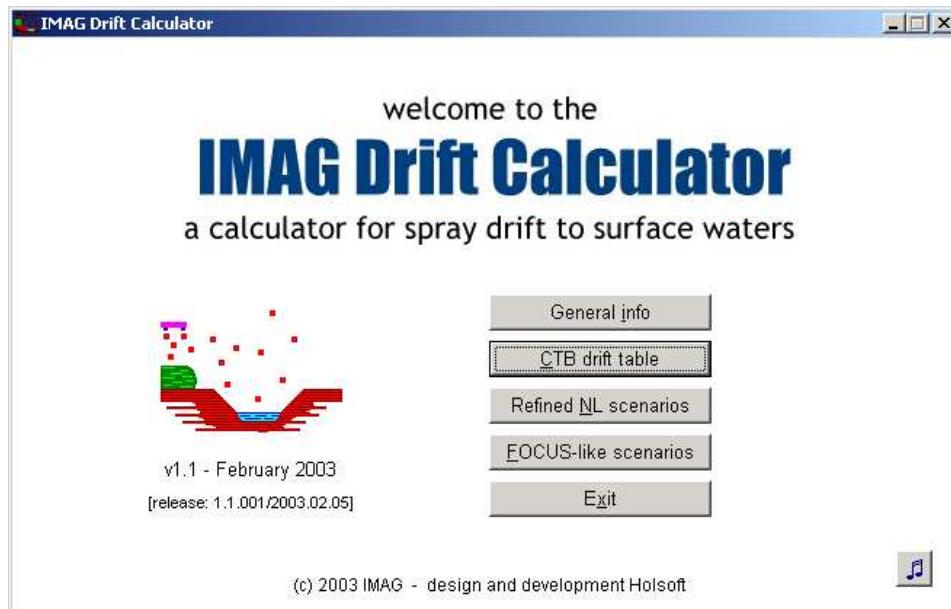

**Figure 5** Opening window of the drift calculator, showing the main menu.

## 4 Using the IMAG Drift Calculator

The drift calculator currently has three main calculation units, or scenario sets:







- CTB table
- Refined NL scenarios
- FOCUS-like scenarios

Each unit has its own window. Various interactive processes by the user are performed by clicking *action buttons*. These buttons are very similar for the three calculation units, and will be explained first (Section 4.1). How to use each of the three units is explained in Sections 4.2 through 4.4. Finally, Section 4.5 deals with the calculation of a crop free zone.

### 4.1 Pictogram buttons

The calculator windows comprise small buttons for various actions. Each button has its own pictogram, which is explained in the table below. The column *text reference* specifies the button name that will be used in this manual to refer to one of these buttons.

**Table 2.** Action buttons; pictograms and explanations.

<i>button</i>	<i>text reference</i>	<i>explanation</i>
	EXIT	closes the current window and return to previous window (usually main menu).
	HELP	opens file with on-line help on using the current window
	SAVE	saves current spray drift and settings in a data file (using the corresponding scenario folder and the next run index number).
	TABLE	opens a window with a table showing possible crops and their geometry, and a table showing possible water bodies.
	CALCZONE	opens a window to calculate the crop free zone, given a specified value of spray drift.
	SAVEBMP	saves the current window as a bitmap.

Some windows contain only a few of these buttons. A more comprehensive description of the action of each button is given in the sections below.

#### 4.1.1 EXIT button

Clicking the EXIT button closes the current window and the user returns to the previous window. Usually this is the main window (when closing one of the three scenario

windows). When closing a window showing selection tables, or the window for calculating the crop free zone, the corresponding scenario window will return.

#### 4.1.2 HELP button

The HELP button opens the help file *IDC.hlp* at the page corresponding to the current window of the calculator.

#### 4.1.3 SAVE button

By clicking this button the calculated drift to the water surface, together with the corresponding settings of crop type, geometry and water body are stored into a text file. Obviously, this button is available on scenario windows only (CTB table, refined NL, FOCUS-like). Each scenario type has its own set of saved data files, stored in separate folders (or subdirectories). If the folder does not exist, it will be created first. Each subsequent data file is named accordingly and based on a run index number (see Table 3). E.g. the first data file from the CTB table scenarios is saved as *\idc\_ctb\ctb0001.dat*. After each saving the corresponding run index number in the run index file (*IDCrunx.dat*) is updated. Though the run index method can deal with many files (9999 per calculation unit), eventually there may come an occasion when the storage is full. See Section 5.1 how to proceed in that case.

**Table 3.** Saving data files per scenario; folder names and data file names.

<i>Scenario type</i>	<i>Scenario folder name</i>	<i>Data file name</i> <sup>1</sup>
CTB table	\idc_ctb	CTBnnnn.dat
Refined NL	\idc_nl	NLnnnn.dat
FOCUS-like	\idc_fcs	FCSnnnn.dat

<sup>1</sup> *nnnn* is based on run index number: 0001...9999.

#### 4.1.4 TABLE button

After clicking this button a new window pops up, showing two tables: (1) a table with all possible crops and corresponding spray applications in the current scenario set, (2) a table with possible water bodies. The TABLE button is available from the *Refined NL* and *FOCUS-like* calculation units.

For each crop several parameters are listed (distances and heights to describe the geometry). The table of crop types and application techniques is different for the two scenario sets. In the table for *Refined NL* scenarios only crops and applications are shown for which statistical drift curves exist. For *FOCUS-like* scenarios all crops defined by FOCUS (2002; see Appendix B) are listed, together with their *equivalent crop*, if present (see Chapter 1, page 6).

The second table shows the water bodies available for the current scenario set. This table has the same structure for both scenario sets, though the list of available water bodies differs. Further information on this window with tables is given in Sections 4.3 and 4.4.

#### 4.1.5 CALCZONE button

The *crop free zone* is defined by the distance from the centre of the last crop row to the top of the (first) bank. The CALCZONE button opens a new window to calculate the crop free zone for a given value of spray drift to the water surface. Crop type, water body and geometry belong to the currently selected scenario. The CALCZONE button is available for *Refined NL* and *FOCUS-like* scenarios only. In Section 4.5 the calculation of the crop free zone is explained in detail.

#### 4.1.6 SAVEBMP button

This button (available for *Refined NL* and *FOCUS-like* scenarios) allows the user to save the current window as a bitmap file in the corresponding scenario folders (*\idc\_nl* and *\idc\_fcs*). File names are *NLrefin.bmp* and *FCSlike.bmp*, respectively. If such a file already exists, the user is prompted to overwrite the existing file or cancel the saving procedure. If the user would like to save more than one bitmap, e.g. for different scenarios within the same calculation unit, the user has to rename bitmap files himself from within the file management system (e.g. Windows Explorer).

## 4.2 CTB drift table

The simplest scenario set in the IMAG Drift Calculator is the CTB table. The corresponding window is shown in Figure 6. It contains a selection box for crop type (including some applications), and a set of radio buttons to select growth stage (for fruit trees only). The averaged spray drift to an adjacent ditch is returned in a small text box. This is the set of scenarios currently used by the Board for the Authorization of Pesticides in the Netherlands (CTB) in its standard first tier exposure assessment (see Table 4).

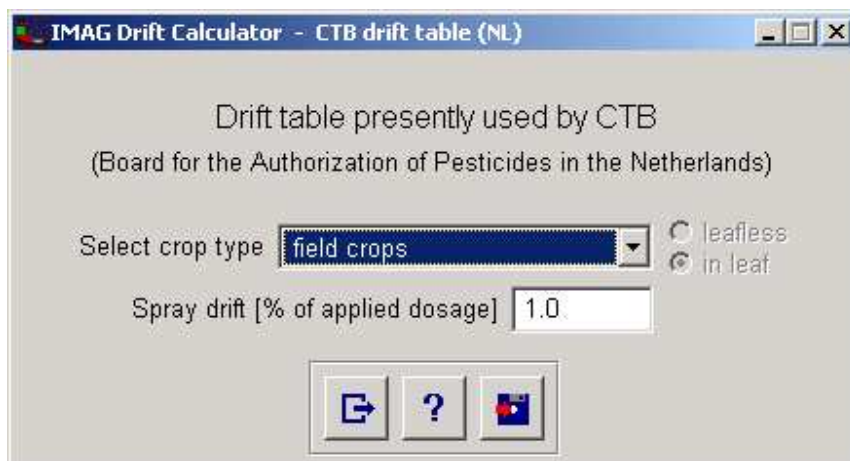

**Figure 6** Window for the CTB drift table.

**Table 4.** CTB drift table, currently used in the Netherlands (CTB website, 2003; Huijsmans, et al., 1999; Van de Zande, et al., 2001).

Crop type	Application	Spray drift [% of applied dosage]	
		In leaf	Leafless
Field crops		1.0	
Bulb crops		1.0 <sup>a</sup>	
Nursery trees, spindles		0.8	
Nursery trees, transplanted		2.8	
Bush and hedge shrubbery		1.0 <sup>a</sup>	
Fruit trees	conventional	7.0	17 <sup>b</sup>
Fruit trees	tunnel sprayer	1.0	2.5 <sup>b</sup>
Fruit trees	with windbreak	0.7	5.1
Fruit trees	sensor-equipped sprayer	3.4	14
Fruit trees	outer row sprayed single-sided	4.2	11
Fruit trees	with emission shield	2.8	6.8 <sup>b</sup>
Fruit trees	sprayer with reflection shields	3.2	7.7 <sup>b</sup>
Fruit trees	with 6m crop-free zone	2.7	6.7 <sup>b</sup>

<sup>a</sup> assumed to be equal to drift for field crops

<sup>b</sup> derived from in-leaf case using factor 2.5 (see Section 2.4)

The CTB table consists of only a few crop types (field crops, nursery trees and fruit trees). Drift for bulb crops and bush and hedge shrubbery is estimated to be equal to drift for field crops. For fruit trees several application techniques are distinguished, as well as growth stage (early spray applications: trees without leaves; and late applications: trees in leaf). In fact using a windbreak or emission shield actually refers to the orchard layout, but these situations are considered as part of the application technique in this report. The sensor-equipped sprayer has the ability to detect whether a crop (i.e. tree) is present or not, while driving by. No refinement has been made for weather conditions. In all cases fruit trees correspond to Dutch orchards, with trees typically 2-3 m high.

Disregarding small differences due to rounding off, the given value of drift for field crops (1%) is identical to that of a potato crop sprayed with drift reducing nozzles (see *Refined NL* scenarios, Section 4.3). Similarly, fruit trees (conventional application; drift 7% and 17%) from the CTB table correspond with those from the *Refined NL* scenarios.

### 4.3 Refined NL scenarios

The *Refined NL* scenario set offers a more versatile approach to calculate drift to surface waters. It covers several crops, and for some crops several application techniques. Figure 7 shows the window for this scenario set. In the upper left panel the crop type and application technique can be selected. For most crop types, however, only a conventional application is available, in which case the drop-down list for this topic is disabled. In all cases the water body is a standardized Dutch ditch (Huijsmans, et al., 1997), and therefore its selection box is disabled. Water depth is fixed at 0.3 m (Beltman and Adriaanse, 1999), and consequently the bottom of the ditch has width 0.4 m. With respect to the calculation of spray drift to a *surface*, the corresponding *volume* below that surface is not a relevant parameter; in fact the ditch geometry below the water level does not affect spray drift results at all.

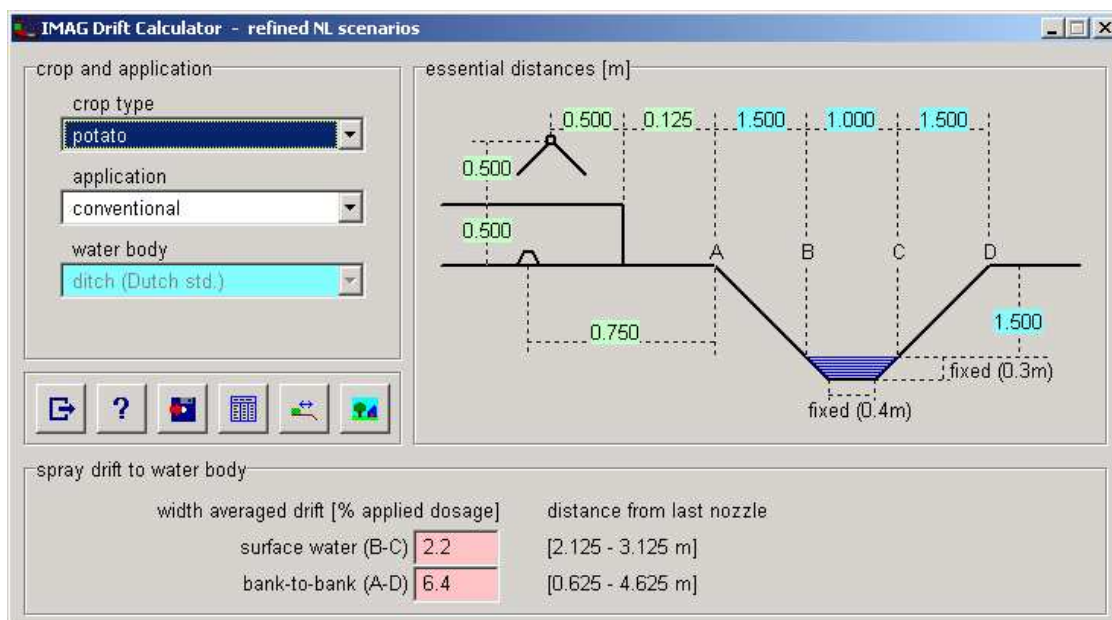

**Figure 7** Window for the *Refined NL* scenarios, layout for field crops.

The drop-down list of available crops corresponds to the list of available drift curves (see Table 5). A detailed description of all crops and applications is given in Appendix A. At the moment, application techniques other than conventional are present only for a potato crop.

**Table 5.** List of crop types and application techniques for which the relation between spray drift (ground deposits) and downwind distance is established statistically.

Crop type	Application technique	Abbreviation in drop-down list
Potato	Conventional	
	Raised sprayer boom	+raised boom
	Conventional + air assistance	+air assistance
	Raised sprayer boom + air assistance	+raised boom & air assist.
	Drift reducing nozzles	
	Drift reducing nozzles + air assistance	+dr.red.nozz. & air assist.
Flower bulb	Conventional	
Sugar beet	Conventional	
Cereals	Conventional	
Fruit trees, in leaf	Conventional (cross-flow)	
Fruit trees, leafless	Conventional (cross-flow)	
Bare soil	Conventional	

The bottom panel shows calculated drift values onto the water surface (ranging from point B to C), and onto the water body including the banks (bank-to-bank drift; A to D). The distance ranges, shown adjacent to the drift values, represent distances with respect to the position of the last nozzle. Drift values are width averaged, i.e. they represent the average value for the given distance range. In practice the spray deposits near the left-hand side of that range will be much higher than the averaged value, while near the right-hand side deposits will be less than average. Often the deposits on the left bank are relatively high, leading to a bank-to-bank drift average which is higher than that for the water surface only.

In case of fruit trees the graphical layout is slightly adapted, see Figure 8. Though this layout may seem to imply that a cross-flow sprayer applies pesticides only single-sided, in practice this is only true for the last row with the sprayer driving between last row and ditch. When the sprayer drives between the last two rows, it applies pesticides to both sides (see Huijismans, et al., 1999). For fruit trees the distance ranges corresponding to the calculated drift values represent distances with respect to the last row of trees, since the position of the last nozzle is undefined.



The screenshot shows a software window titled "IMAG Drift Calculator - selection tables (refined NL scenarios)". It contains two tables. The first table, "Table of crop types and applications", lists various crops and their application techniques with associated distance and height values. The second table, "Table of water body types", lists water body descriptions with their respective parameters.

Crop type	Application technique	Noz-Edg	Edg-Bnk	Row-Bnk	Hnozz	Hcrop
potato	conventional	0.500	0.125	0.750	0.500	0.500
potato	+raised boom	0.500	0.125	0.750	0.700	0.500
potato	+air assistance	0.500	0.125	0.750	0.500	0.500
potato	+raised boom & air assist.	0.500	0.125	0.750	0.700	0.500
potato	+drift reducing nozzles	0.500	0.875	1.500	0.500	0.500
potato	+dr.red.nozz. & air assist.	0.500	0.875	1.500	0.500	0.500
flower bulb	conventional	-0.250	1.500	1.500	0.500	0.300
sugar beet	conventional	0.750	0.000	0.500	0.500	0.500
cereals	conventional	0.250	0.250	0.250	0.500	0.500
fruit trees, in leaf	conventional	0.000	1.500	3.000	0.000	2.500
fruit trees, leafless	conventional	0.000	1.500	3.000	0.000	2.500

Water body description	Bnk	SrfWa	WaLvl	Bnk-Bnk
ditch (Dutch std.)	1.500	1.000	1.500	4.000

**Figure 9** Table of available crops and spray applications, for the *Refined NL* scenarios, with corresponding settings of distances and heights. The water body list contains only one type (Dutch standardized ditch).

With flower bulbs, the last nozzle has a negative distance to the crop edge: this nozzle is positioned outside the crop area (i.e. over the edge of the crop). With fruit trees, a cross-flow sprayer is assumed. In this case the distance from nozzle to crop edge has no practical meaning is therefore is set to zero. The same holds for nozzle height above the crop.

The table of water bodies merely lists the standardized Dutch ditch, in this case of *Refined NL* scenarios. The abbreviations used are:

- *Bnk*: horizontal width of a bank;
- *SrfWa*: width of the water surface;
- *WaLvl*: depth of the water surface below ground level; note that this does not say anything about the depth of the water body itself;
- *Bnk-Bnk*: bank-to-bank distance: the distance from the top of the left bank to the top of the right bank; clearly this must equal  $2 * Bnk + SrfWa$ .

#### 4.4 FOCUS-like scenarios

The window for the *FOCUS-like* scenarios (Figure 10) is very similar to that of the *Refined NL* scenarios. The crops from the drop-down list follow the list of the FOCUS Surface Water group (see Appendix B, Table B.1). However, the necessary drift/distance curves are only available for the crops and applications as given in the *Refined NL* scenarios. Therefore, for each *FOCUS-like* crop an equivalent crop is selected from the available list of Dutch crops. *FOCUS-like* crop and equivalent crop may match closely (e.g. *FOCUS-like* potato matches ‘Dutch’ potato) or loosely (e.g. similar crop shape and height). Even with the loose ‘shape/height’ criteria, some *FOCUS-like* crops could not be matched to an equivalent crop. In Appendix B, Table B.1 the complete list of crop matching is shown.

After selecting a crop type, a message appears showing which is the equivalent crop, or showing that an equivalent crop was not found. In the first case, the crop height in the graphical layout (upper-right panel) is that of the equivalent crop. Since FOCUS does not define position of nozzles, the shown distance and height of the last nozzle correspond to the equivalent crop/application as well. In case no equivalent crop could be found, crop height shown in the graph is that of the actual *FOCUS-like* crop (and background colour is changed to yellow instead of green), while position of the last nozzle and the last row are undefined and marked ‘xxx’.

By default the application technique always is ‘conventional’, i.e. common practice. When the selection box ‘*include non-convent'l applications*’ is marked, for some crops additional applications become available. At present this is only the case when the equivalent crop is potato.

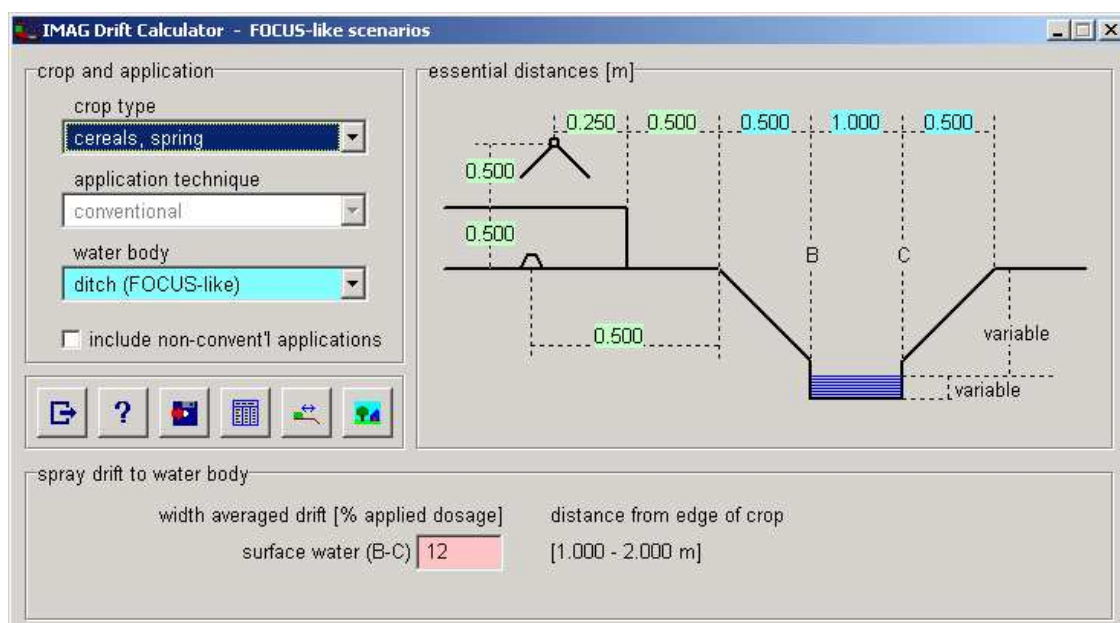

Figure 10 Window for the *FOCUS-like* scenarios.

Note that the layout does not always represent the actual sprayer: especially large crops (e.g. trees) will not be sprayed using a conventional boom sprayer.

The drop-down list for water bodies covers three water bodies corresponding to ‘ditch’, ‘stream’, and ‘pond’ from the FOCUS Surface Water criteria (see Appendix B, Table B.3 for settings). Note that the *FOCUS-like* ditch has other shape and size than the standardized Dutch ditch from the *Refined NL* scenarios. Typically, where the Dutch ditch is trapezium shaped (though fixed in size), the *FOCUS-like* water bodies have a rectangular cross-section with variable water depth. Thus a varying water level does not affect the width of the water surface, and consequently does not affect calculated drift.

The bottom panel shows calculated drift onto the water surface. Since in FOCUS the bank-to-bank drift is not considered (as with *Refined NL* scenarios), this is left out of the current window. Yet, when saving the settings and results (SAVE-button), the bank-to-bank drift value is saved too. Whereas with *Refined NL* scenarios the distance ranges (A-D, B-C) are given with respect to the last nozzle (or the last crop row, with fruit trees), for *FOCUS-like* scenarios the range (B-C) is shown with respect to the edge of the crop. This is the better choice, since actually nozzle position as well as position of the last row are undefined in *FOCUS-like* scenarios.

The screenshot shows the 'IMAG Drift Calculator - selection tables (FOCUS-like scenarios, with extended applications)' window. It contains two tables:

**Table of crop types and applications**

Crop type	Equiv crop	Appl technique	Noz-Edg	Edg-Bnk	Row-Bnk	Hnozz	Hcrop	Hequiv
cereals, spring	cereals	conventional	0.250	0.500	0.500	0.500	0.800	0.500
cereals, winter	cereals	conventional	0.250	0.500	0.500	0.500	0.800	0.500
citrus	(no equiv fit)	(undef)	(undef)	3.000	(undef)	(undef)	3.000	(undef)
cotton	(no equiv fit)	(undef)	(undef)	0.800	(undef)	(undef)	1.200	(undef)
field beans	potato	conventional	0.500	0.800	1.425	0.500	0.600	0.500
field beans (ext.)	potato	+raised boom	0.500	0.800	1.425	0.700	0.600	0.500
field beans (ext.)	potato	+air assistance	0.500	0.800	1.425	0.500	0.600	0.500
field beans (ext.)	potato	+raised boom & air assist.	0.500	0.800	1.425	0.700	0.600	0.500
field beans (ext.)	potato	+drift reducing nozzles	0.500	1.550	2.175	0.500	0.600	0.500
field beans (ext.)	potato	+dr.red.nozz. & air assist.	0.500	1.550	2.175	0.500	0.600	0.500
grass/alfalfa	bare soil	conventional	0.250	0.500	0.500	0.500	0.200	0.050

**Table of water body types**

Water body description	Bnk	SrfWa	WaLvl	Bnk-Bnk
ditch (FOCUS-like)	0.500	1.000	(var)	2.000
stream (FOCUS-like)	1.000	1.000	(var)	3.000
pond (FOCUS-like)	3.000	30.000	(var)	36.000

**Figure 11** Table of available crops and spray applications, for *FOCUS-like* scenarios, with settings of distances and heights. Non-conventional application techniques are shown as well. The water body list contains standardized *FOCUS-like* water bodies only.

Pressing the TABLE button opens a window with two tables (Figure 11). The upper table lists crop types and application techniques. The following columns are shown:

- *Crop type*: list of crop types from FOCUS (2002);
- *Equiv crop*: equivalent crop type (best fitting crop) from the *Refined NL* crop type list;
- *Appl technique*: spray application technique; by default ‘conventional’; when equivalent crop is ‘potato’, extended (non-conventional) applications are available (see Table 5, page 22 for an explanation of abbreviations);
- *Noz-Edg*: distance from last spray nozzle to the edge of the crop; since nozzle positions are defined for the ‘equivalent application’ only, this distance is undefined (‘*undef*’) when no equivalent crop is available;
- *Edg-Bnk*: distance from the edge of the crop to the top of the left bank (from FOCUS, 2002; see Appendix B, Table B.1);
- *Row-Bnk*: distance from the centre of the last crop row to the top of the left bank (this distance is also called crop free zone); though the edge of the crop is defined in FOCUS, the position of the last crop row is not, but follows from the situation with the equivalent crop; when an equivalent crop is not available, *Row-Bnk* distance therefore is undefined (‘*undef*’);
- *Hnozz*: height of the nozzle above the crop canopy (equivalent crop only);
- *Hcrop*: height of the crop canopy above ground level (FOCUS, 2002; see Appendix B, Table B.1);
- *Hequiv*: height of the equivalent crop canopy above ground level; this height may differ from that according to the FOCUS definitions.

The lower table lists available water bodies for the *FOCUS-like* scenarios. The same abbreviations are used as in the case of *Refined NL* scenarios (see Section 4.3, page 24). The properties of the water bodies are defined by FOCUS (2002; see also Appendix B, Table B.3). Note that the depth of the water surface below ground level is variable; yet this does not affect width of the water surface (see also layout in Figure 10).

## 4.5 Crop free zone calculation

The *crop free zone* is defined as the distance from the centre of the last crop row to the top of the (first) bank. Since the crop in a row has a certain non-zero width, the distance between the (visual) edge of the crop and the top of the bank usually is smaller than the crop free zone.

On the windows for *Refined NL* and *FOCUS-like* scenarios the CALCZONE button is present. Pressing this button opens a new window to calculate the crop free zone for a given value of spray drift to the water surface (see Figure 12). Crop type, water body and geometry belong to the currently selected scenario. The (width averaged) drift value has to be entered manually (default value: 1% of the applied dosage). The returning value is the crop free zone necessary to produce a spray drift equal to the given value.

The required crop free zone is calculated by iterating this distance until the calculated drift equals the entered drift value. Resolution of the estimated crop free zone is better than 1 cm. The result is shown in the lower edit-box, obviously after pressing the button marked 'calculate zone'. Specifying a low drift value results in a relatively large crop free zone. On the other hand, if a relatively high drift value is entered, it may turn out that no crop free zone is necessary. Since the regression curves have a limited reach of validity with respect to distance, zones larger than about 25 m are truncated.

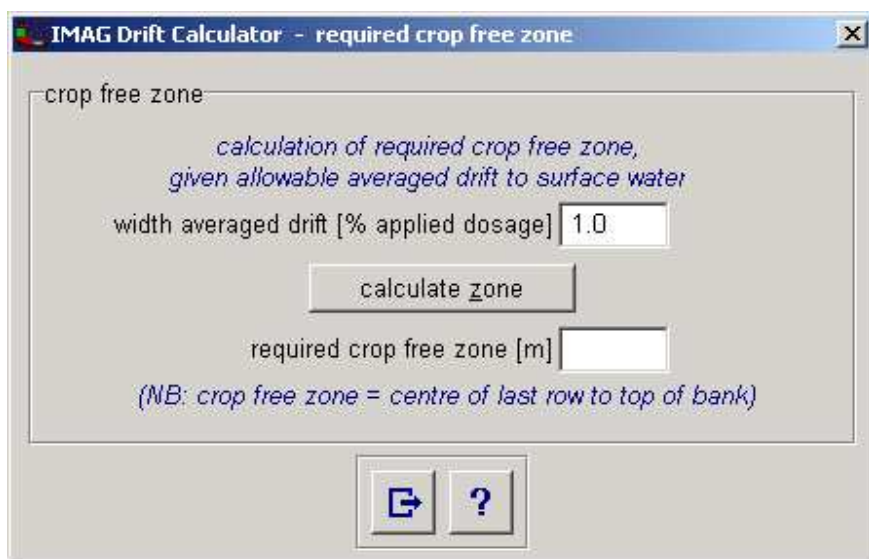

**Figure 12** Window to calculate the crop free zone for a given value of spray drift.

## 5 Data control

### 5.1 Resetting the run index system

Though the run index system allows 9999 scenarios to be saved for each type of scenario (CTB, Refined NL, FOCUS-like), in principle it is possible that the run index reaches its maximum value. Besides, the user may want to clean up his old and unused trials. The following procedure explains how to reset the run index system for a fresh start.

Close the drift calculator first (if it is still running). If the old trials are to be saved for future reference, the scenario folders (*\idc\_ctb*, *\idc\_nl*, *\idc\_fcs*) should be zipped and stored in a different place (e.g. in the main folder *IMAG Drift Calculator* or in a newly named folder). Then delete the scenario folders completely, and delete the run index file *IDCrunx.dat* as well. When the drift calculator is restarted, a fresh and new run index file is created, and saved scenarios will have run index numbers starting at 1 again.

If only the run index file is deleted, without cleaning up the scenario folders, the next time a scenario is saved, the user is prompted to allow an existing scenario file to be overwritten. If the user chooses not to overwrite the old file, the new scenario cannot be saved. On the other hand, if only the scenario folders are deleted or emptied and the run index file is left unchanged, the run index system does not notice any change and will proceed as before (i.e. not start with index 1 but with the index provided by the run index file). Therefore cleanup of the run index system should always include (1) deleting the run index file, (2) deleting (or emptying) the scenario folders.

### 5.2 The saved data file

The text-box below (Table 6) shows an example of the structure of the saved data file. It consists of four blocks of lines. Comment lines start with #, data lines start with \$. Data lines follow the structure \$<key> = <value>.

The first block starts with two lines of general information, followed by four lines showing the scenario set to which the data belong (in this case *Refined NL*), the drift values to surface water and bank-to-bank drift, and the type of drift curve (50<sup>th</sup> percentile in this case).

The next three blocks consist of parameters to define the particular scenario. The second block shows crop related parameters. Added to type, height and growth stage of the actual crop, are type and height of the equivalent crop. In case of *Refined NL* scenarios equivalent crop obviously is identical to actual crop. In case of *FOCUS-like* scenarios, type and height may differ. Finally, horizontal positioning of the crop is defined by crop free zone and distance from edge to top of the bank.

The third block shows sprayer related parameters: application type and positioning of the last nozzle. In case of *FOCUS-like* scenarios, position of the nozzle refers to the equivalent crop and application rather than to the actual crop.

The fourth block consists of parameters with respect to the selected water body. The type of water body and essential parameters defining its geometry are shown. Since depth of the water body itself is not essential for calculating drift, this parameter is not included.

**Table 6.** Example of saved data file, showing calculated drift in first block, and essential parameters in next three blocks.

```
#IMAG Drift Calculator v1.1 - (c) 2003, IMAG / Holsoft
#Spray Drift Calculator for Surface Waters
$drift case = NL refined
$surface water drift, % applied dosage = 2.2
$bank-to-bank drift, % applied dosage = 6.4
$curve type = 50%ile

#crop related parameters:
$crop type = potato
$crop stage = undefined
$crop equiv = potato
$actual height = 0.500
$equiv height = 0.500
$crop free buffer zone = 0.750
$edge of crop to top of bank = 0.125

#spray application related parameters:
$application type = conventional
$last nozzle to edge to crop = 0.500
$nozzle height above crop canopy = 0.500

#water body related parameters:
$water body type = ditch (Dutch std.)
$bank-to-bank width = 4.000
$water surface width = 1.000
$single bank width (horiz) = 1.500
$water surface below ground level = 1.500
```

## 6 Future developments

Currently, the IMAG Drift Calculator is limited to the regression curves for only four arable crops, two fruit crop stages, and bare ground. Non-conventional application techniques are only available for a potato crop. These cases imply a total of 12 regression curves. Future development will need to focus on a larger variety in crops and applications. Particularly extending the calculator to non-matched crops in the *FOCUS-like* scenario set should have attention.

Currently the regression curves are averaged results for a specified crop and a specified application technique, but with varying weather conditions (e.g. wind speed). Accounting for the effect of weather conditions may need focus as well.

So far only standardized water bodies are used. In the *Refined NL* scenarios only a single ditch is available; in *FOCUS-like* scenarios the three water bodies specified by the FOCUS Working Group can be selected. Selection of non-standard water bodies (e.g. with a user defined geometry) is a further topic for future development of the calculator.

## 7 Glossary

### ***Application technique***

Description of the method how pesticide is applied; usually description of the sprayer, its nozzles and possibly additional features (e.g. air assistance). In a wider context, driving speed and height of the sprayer boom above the crop are part of the application technique as well. A *conventional* application technique refers to the common practice, which usually differs for different crops. Clearly spray equipment for field crops is very different from equipment for fruit trees.

### ***Applied dosage***

The intended amount of pesticide or spray liquid per unit of area of the field. Usually the amount of spray drift (particularly downwind deposits) is presented as a percentage of applied dosage.

### ***Bank-to-bank width***

Usually a water body has two sloping banks on opposite sides of the water surface. The distance from one top of a bank to the top of the other bank is called the bank-to-bank distance. With a pond one may not distinguish two banks, but there always is an opposite side. With respect to spray drift calculations, bank-to-bank distance always is measured perpendicular to the edge of the crop.

### ***Crop free zone***

By definition the distance from the centre of the last crop row to the top of the first bank. Since a crop row has a non-zero width, the distance between the actual edge of the crop and the top of the bank is less than the crop free zone.

### ***Edge nozzle***

Type of spray nozzle placed at the tip of the sprayer boom; it produces a flat fan with a reduced top angle, and directed slightly sideward. When used properly, this nozzle only sprays in the direction of the (edge of the) crop, it does not spray over the edge.

### ***Edge of the crop***

The visual border of the crop canopy. In practice this border hardly ever is present as a well-defined edge, yet for calculation purposes it is convenient to define such an edge at an exact location.

### ***Equivalent crop***

The drift calculator is based on statistical relations between spray deposits and downwind distances, for various crops under specified weather conditions and application techniques. In general, these situations do not perfectly correspond to FOCUS-like scenarios. For these scenarios, therefore, a best choice is made from the available set of situations. This best choice is named *equivalent crop*. Though

the name suggests a crop only, it also implies a certain application technique (marked as *conventional*).

***Reduced-drift nozzle***

Type of nozzle that produces a spray which is courser than that of a conventional nozzle, at the same liquid flow rate and pressure. Used as a measure to reduce drift, in the Netherlands it is often combined with the use of *edge nozzles*.

***Spray drift***

When pesticides are applied by a spraying technique, part of the droplets may float downwind and deposit off-target, e.g. on the surface of a water body. Though sometimes the term *spray drift* is reserved for droplets remaining airborne for a long time, in this calculator the term is used for all spray drops depositing downwind. The term refers to the process of drift, as well as to the volume of deposited spray. It is clear from the context which of these is meant.

***Top of the bank***

The (location of the) onset of the sloping bank of a water body.

***Width averaged drift***

Value of spray drift, averaged over a specified width. In case of water bodies, the specified width is either the actual width of the water surface or the bank-to-bank width. Since drift decreases with increasing downwind distance, the actual distribution of spray onto the water surface may be very uneven. Width averaged drift therefore may serve its purpose, but in general does not reflect the actual distribution of pesticide onto a surface.

In the drift calculator all drift values are width averaged.

## References

- Arvidsson, T. (1997)  
Spray drift as influenced by meteorological and technical factors. A methodological study. Swedish University of Agricultural Sciences, Acta Universitatis Agriculturae Sueciae, Agraria 71. 144pp.
- BBA (2000)  
Verfahren zur Eintragung von Pflanzenschutzgeräten in de Abschnitt “Abtrift” des Verzeichnisses "Verlustmindernde Geräte",  
Biologische Bundesanstalt für Forst- und Landwirtschaft , Braunschweig. 9p.
- Beltman, W.H.J., and Adriaanse, P.I. (1999)  
Proposed standard scenarios for a surface water model in the Dutch authorization procedure of pesticides.  
Report 161, Staring Centre (SC-DLO), Wageningen, the Netherlands.
- CTB Website (visited February 2003)  
home (English entry): [http://www.ctb-wageningen.nl/index\\_uk.html](http://www.ctb-wageningen.nl/index_uk.html);  
tables with drift values (in Dutch): [http://www.ctb-wageningen.nl/htbB4I\\_A.pdf](http://www.ctb-wageningen.nl/htbB4I_A.pdf)
- FOCUS (2002)  
FOCUS Surface Water Scenarios in the EU Evaluation Process under 91/414/EEC.  
Report of the FOCUS Working Group on Surface Water Scenarios,  
EC Document Reference SANCO/4802/2001-rev.1 (June 2002); 221 pp.
- Ganzelmeier, H., Rautmann, D., Spangenberg, R., Streloke, M., Hermann, M., Wenzelburger, H.J., Walter, H.F. (1995)  
Untersuchungen zur Abtrift von Pflanzenschutzmitteln. Ergebnisse eines bundesweiten Versuchsprogrammes. Mitteilungen aus der Biologische Bundesanstalt für Land- und Forstwirtschaft, Heft 304, Berlin. 111p.
- Huijsmans, J.F.M., Porskamp, H.A.J., Heijne, B. (1993)  
Orchard tunnel sprayers with reduced emission to the environment. Results of deposition and emission of new types of orchard sprayers.  
Proceedings A.N.P.P.-B.C.P.C. Second International Symposium on Pesticides Application, Strasbourg, 22-24 sept. 1993, BCPC, Vol. 1/2, p. 297-304.
- Huijsmans, J.F.M., Porskamp, H.A.J., Van de Zande, J.C., (1997)  
Drift(beperking) bij de toediening van gewasbeschermingsmiddelen  
(*Spray drift (reduction) in crop protection application technology*) Report 97-04;  
Instituut voor Milieu- en Agritechniek (IMAG), Wageningen, the Netherlands, 41 pp  
(in Dutch, with summary in English)

- Huijsmans, J.F.M., Van de Zande, J.C., Porskamp, H.A.J. (1999)  
Studie driftpercentages vanaf 2000. Werkdocument. Nota P-99-51; April 1999;  
Instituut voor Milieu- en Agritechniek (IMAG), Wageningen, the Netherlands; 27 pp  
(in Dutch).
- Jong, A de, Michielsen, J.M.G.P., Stallinga, H., Van de Zande, J.C. (2000)  
Effect of sprayer boom height on spray drift. Mededelingen Faculteit  
Landbouwwetenschappen, Universiteit van Gent, 65/2b, 2000. 919-930
- Michielsen, J.M.G.P., Van de Zande, J.C. (1998)  
Effect of coarse spray quality nozzles and air assistance on spray drift when spraying  
potatoes. IMAG-DLO Internal Note 98-58, Wageningen. 22p. (in Dutch, not published)
- Michielsen, J.M.G.P., Stallinga, H., Van de Zande, J.C. (1999)  
Drift reduction when using low drift nozzles, an end nozzle and air assistance.  
Institute of Agricultural and Environmental Engineering, IMAG-DLO Internal Note  
99-111, Wageningen. 31p. (in Dutch, not published)
- MYCPP (1991)  
Multi Year Crop Protection Plan. Tweede Kamer, Vergaderjaar 1990-1991, 21677,  
nrs3-4, SDU Uitgeverij, 's-Gravenhage. 298pp. (in Dutch)
- Porskamp, H.A.J., Michielsen, J.M.G.P., Van de Zande, J.C. (1997)  
Emission reducing pesticide application in flowerbulb growing. Drift deposition of an  
air-assisted field sprayer, a sprayer with a shielded sprayer boom and a tunnel  
sprayer. Institute of Agricultural and Environmental Engineering, IMAG-DLO Report  
97-08, Wageningen. 36p. (in Dutch with English summary)
- Porskamp, H.A.J., Michielsen, J.M.G.P., Huijsmans, J.F.M., Van de Zande, J.C. (1995)  
Emission-reducing pesticide application in potato growing. The effects of air  
assistance, nozzle type and spray-free zone on the drift deposition outside the field.  
Institute of Agricultural and Environmental Engineering, IMAG-DLO Report 95-19,  
Wageningen. 39p. (in Dutch with English summary)
- SDTF (1997)  
A summary of ground application studies.  
Spray Drift Task Force, Steward Ag.Res.Service, Macon. 5pp.
- Southcombe, E.S.E., Miller, P.C.H., Ganzelmeier, H., Van de Zande, J.C., Miralles, A.,  
Hewitt, A.J. (1997)  
The international (BCPC) spray classification system including a drift potential  
factor. Proceedings of the Brighton Crop Protection Conference - Weeds, November  
1997. Brighton. UK. p.371-380
- Stallinga, H., Michielsen, J.M.G.P., Van de Zande, J.C. (1999)  
Effect of crop height on spray drift when spraying a cereal crop.

Instituut voor Milieu- en Agritechniek, IMAG-DLO Nota 99-71, Wageningen. 23pp.  
(in Dutch, not published)

Ter Horst, M.M.S., Adriaanse, P.I. Beltman, W.H.J. (draft 27-sep-2002)  
TOXSWA in FOCUS, version 1.1.1. User's guide version 1.0  
Alterra Report 586; Alterra, Green World Research, Wageningen; the Netherlands.

Van de Zande, J.C., Stallinga, H., Michielsen, J.M.G.P. (2000a)  
Spray drift when applying herbicides in sugarbeet and maize using a band sprayer.  
Mededelingen Fac.Univ. Gent, 65/2b: 945-954

Van de Zande, J.C., Porskamp, H.A.J., Michielsen, J.M.G.P., Holterman, H.J.,  
Huijsmans, J.F.M. (2000b)  
Classification of spray applications for driftability, to protect surface water.  
Aspects of Applied Biology 57: 57-65

Van de Zande, J.C., Heijne, B., Wenneker, M. (2001)  
Spray drift reduction in orchard spraying. State-of-the-art December 2001.  
IMAG Report 2001-19; IMAG and PPO-fruit, Wageningen, the Netherlands; 41p. (in  
Dutch with English summary)

Van de Zande, J.C., Parkin, C.S., Gilbert, A.J. (2002)  
Application techniques. Chapter 3  
In: M.F. Wilson, Optimising Pesticide Use, Wiley & Sons (forthcoming)

## Appendix A

**Table A.1** List of available crop types and application techniques, and statistical information for drift calculation.

Crop type	Application technique 1)	Crop height [m]	Last row to edge [m]	Last nozzle to edge [m]	Boom height [m] <sup>2)</sup>	Crop free zone [m] <sup>3)</sup>	Air assist 4)	Wind [m/s] <sup>5)</sup>	#obs 6)	Var expl [%] <sup>7)</sup>	$A_0$ [%] <sup>8)</sup>	$A_1$ [m <sup>-1</sup> ]	$B_0$ [%]	$B_1$ [m <sup>-1</sup> ]
Potato	Conventional	0.5	0.625	0.5	0.5	0.75	-	3.0	110	94	114	1.74	1.29	0.139
	Raised boom				0.7	0.75	-	2.7	83	68	3.53	-	2.18	-
	Air assistance				0.5	0.75	+	2.8	104	88	550	3.23	0.126	0.074
	Raised boom & air assistance				0.7	0.75	+	2.6	58	83	250	2.23	0.86	0.286
	RD nozzles				0.5	1.50	-	3.0	40	-	80	1.9	1.1	0.15
	RD nozzles & air assistance				0.5	1.50	+	4.0	20	-	100	2.2	0.20	0.12
Flower bulb	Conventional	0.3	0.0	-0.25	0.5	1.50	-	4.1	43	98	84	1.79	1.30	0.153
Sugar beet	Conventional	0.5	0.5	0.75	0.5	0.50	-	4.5	26	97	294	2.39	2.44	0.147
Cereals	Conventional	0.5	0.0	0.25	0.5	0.25	-	4.4	40	98	39	0.90	2.28	0.147
Fruit trees, in leaf	Cross-flow	2.5	1.5	n/a	n/a	3.0	n/a	3.0	16	-	48	0.45	2.7	0.091
Fruit trees, leafless <sup>9)</sup>	Cross-flow	2.5	1.5	n/a	n/a	3.0	n/a	n/a	n/a	n/a	120	0.45	6.75	0.091
Bare soil	Conventional	<0.05	0.0	0.25	0.5	0.25	-	4.3	58	94	25	1.50	1.54	0.133

<sup>1)</sup> RD: reduced drift (nozzles)

<sup>2)</sup> height of sprayer boom above crop canopy; n/a: not applicable

<sup>3)</sup> identical to distance from last row to top of first bank; values given correspond to *Refined NL* scenarios

<sup>4)</sup> +: with air assistance; -: no air assistance; n/a: not applicable

<sup>5)</sup> wind speed at 2 m above bare soil, averaged over all trials

<sup>6)</sup> number of observations (i.e. experiments)

<sup>7)</sup> percentage of variance explained by regression

<sup>8)</sup> constants in regression curve:  $A_0$ ,  $A_1$ ,  $B_0$ ,  $B_1$  (see Section 2.6)

<sup>9)</sup> derived from fruit trees in leaf, by using a factor 2.5 in drift enhancement (see Section 2.4)

## Appendix B

**Table B.1** Crop types, distance to top of bank, and crop heights, according to FOCUS (2002); matching of equivalent crops.

Crop type	Edge to bank [m]	Crop height [m] <sup>1)</sup>	Equivalent crop <sup>6)</sup>	Non-matching criteria <sup>7)</sup>
Cereals, spring	0.5	0.8	4	
Cereals, winter	0.5	0.8	4	
Citrus	3	3.0	-	HC
Cotton	0.8	1.2	-	HC
Field beans	0.8	0.6	1	
Grass/alfalfa	0.5	0.2	5	
Hops	3	2.5 <sup>2)</sup>	-	HC
Legumes	0.8	0.6	4	
Maize	0.8	1.8	-	H
Oil seed rape, spring	0.5	0.7	4	
Oil seed rape, winter	0.5	0.7	4	
Olives	3	3.0	-	H
Pome/stone fruit, early applns	3	5.0 <sup>3)</sup>	-	HC
Pome/stone fruit, late applns	3	5.0 <sup>3)</sup>	-	HC
Potatoes	0.75	0.6	1	
Soybeans	0.75	1.7 <sup>2)</sup>	-	H
Sugar beets	0.75	0.6	3	
Sunflowers	0.75	1.8	-	H
Tobacco	1	2.5 <sup>2)</sup>	-	H
Vegetables, bulb	0.5	0.3	2	
Vegetables, fruiting	0.5	0.6	1	
Vegetables, leafy	0.5	0.3	2	
Vegetables, root	0.5	0.3	2	
Vines, early applns	3	0.5 <sup>4)</sup>	-	C
Vines, late applns	3	1.8	-	HC
appln, aerial	5	1.0 <sup>5)</sup>	-	A
appln, hand (crop < 50 cm)	0.5	0.5 <sup>5)</sup>	1	
appln, hand (crop > 50 cm)	3	1.0 <sup>5)</sup>	4	
no drift (incorp or seed trtmt)	0	-	n/a	n/a

<sup>1)</sup> from FOCUS (2002), Appendix C, Table C.1, C.2 (MACRO model settings)

<sup>2)</sup> from FOCUS (2002), Appendix D, Table D.1 (PRZM model settings)

<sup>3)</sup> in MACRO no distinction between early and late application

<sup>4)</sup> in MACRO no distinction between early and late application; crop height chosen in accordance with TOXSWA (early application in vines has crop height <0.5 m)

<sup>5)</sup> arbitrary choice of crop height

<sup>6)</sup> index number of equivalent crop (see Table B.2)

<sup>7)</sup> H = crop is too high; C = shape of crop canopy cannot be matched; A = application technique cannot be matched; n/a = not applicable

**Table B.2** Equivalent crops taken from *Refined NL* scenarios; with index number and crop height

Index number	Crop type	Crop height [m]
1	Potato	0.5
2	Flower bulb	0.3
3	Sugar beet	0.5
4	Cereals	0.5 <sup>1)</sup>
5	Bare soil / grass	<0.05

<sup>1)</sup> range in experimental drift studies: 0.4-0.8 m

**Table B.3** Water body definitions for *FOCUS-like* scenarios, according to FOCUS (2002)

Water body type	Bank width [m] (horizontally)	Water surface width [m]
Ditch	0.5	1.0
Stream	1.0	1.0
Pond	3.0	30.0